

1 各部名稱 Series Component

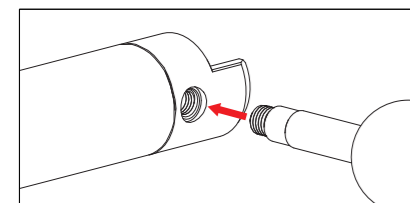
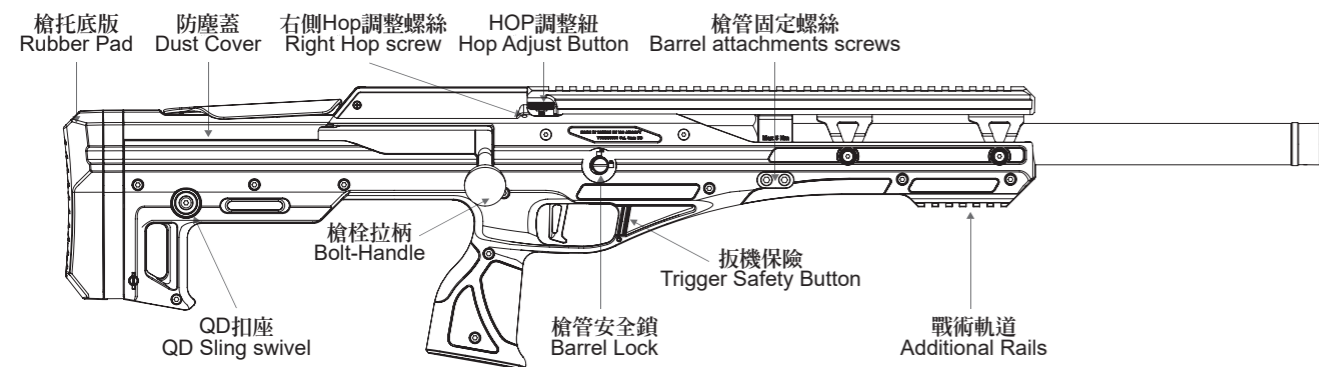
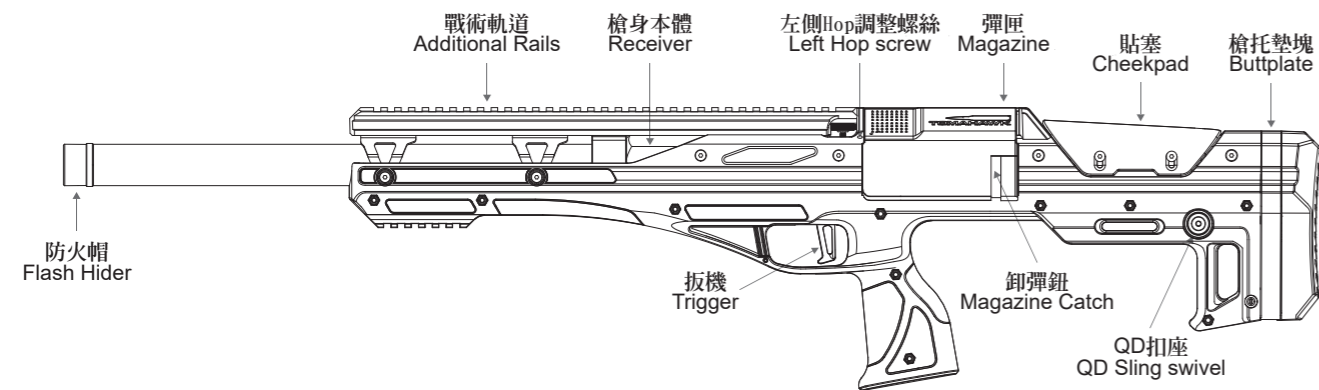

請將拉柄與汽缸頭鎖合方可使用。
備註：建議使用螺絲膠加固。
Please lock the handle with the cylinder head before use.
※ It is recommended to use screw glue for reinforcement.

相關系列產品型號與詳細規格，請以官方網站公布為主。
For related series product models and detailed specifications, please refer to the official website.

2 彈匣使用方式 Magazine Attachment

2-1 裝BB彈方式 Load BBs

使用手或者填彈工具將6mm BBs填入彈匣內。
(裝彈量: 50Rds)
Insert 6mm BBs inside the magazine by using hand or BB loader.
(Capacity: 50Rds)

建議使用 6mm BB彈。
6mm caliber BBs are recommended for optimum performance.

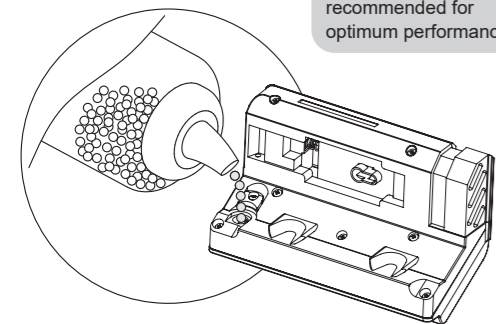

2-2 裝卸彈匣 Magazine Loading and Unloading

1. 以適當手勢拿取彈匣，並持續按壓退彈鈕，並向左側取下彈匣。
1. To release the magazine, pull the magazine leftward after depressing the magazine catch button.

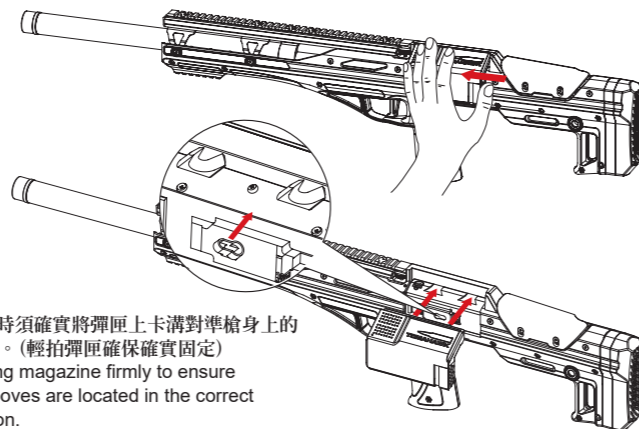

2. 裝彈匣時須確實將彈匣上卡溝對準槍身上的溝槽內。(輕拍彈匣確保確實固定)
2. Inserting magazine firmly to ensure the grooves are located in the correct retention.

3 保險裝置 Safety

3-1 向前推動扳機保險鈕即可解除保險鈕
Slide the safety button to forward position to disengage the safety.

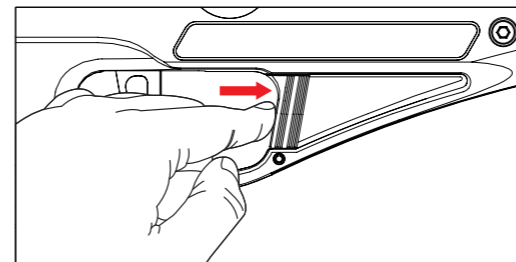

3-2 向後拉動扳機保險鈕即可打開保險鈕
Slide the safety button to backward position to engage the safety.

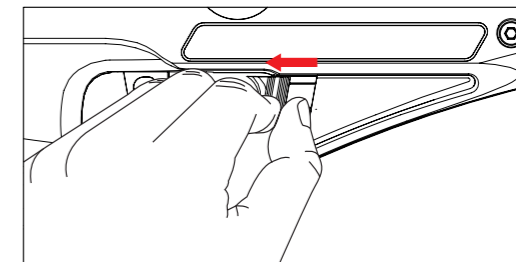

4 槍管安裝與卸下方式 Barrel Assembly and Disassembly Attachment

4-1 卸下槍管 Disassembly Barrel

1. 旋轉放鬆HOP調整鈕及側邊HOP調整螺絲，避免槍裝拆卸時干涉。
1. To release the magazine, pull the magazine leftward after depressing the magazine catch button.
2. 逆時鐘旋轉槍管保險鈕，並確實定在解鎖狀態位置。
2. Rotate the barrel lock button on the "locker open" position.

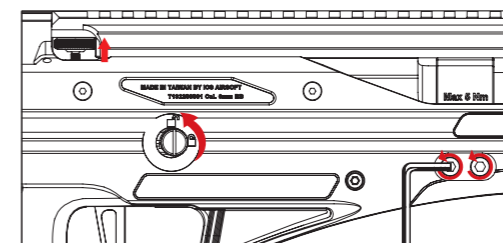

3. 旋轉放鬆槍管固定螺絲。
※不需要卸下螺絲，只要放鬆直到能抽出槍管即可。
3. Rotate and loosen the barrel attachments screws.
※ Don't need to remove it, loosen the screws when you can pull out the barrel is enough.

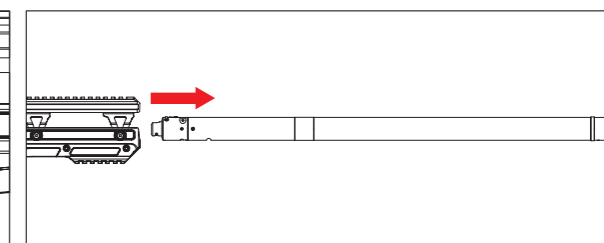

4. 將槍管向前抽出。
※ Make sure that the barrel lock is on "Unlock" position.

4-2 安裝槍管 Assembly Barrel

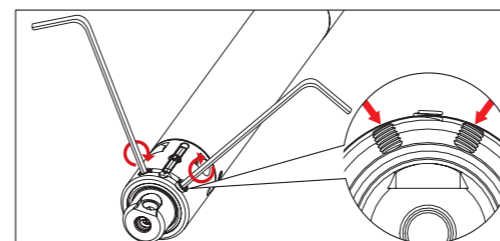

1. 組裝槍管前，需確認HOP調整螺絲在正確位置。
※ 確認調整螺絲高度不可高於HOP座，避免組裝時干涉。
1. Ensure the hop adjust screws are on the correct position before insert the barrel.
※ Make sure the screws won't beyond the hop.

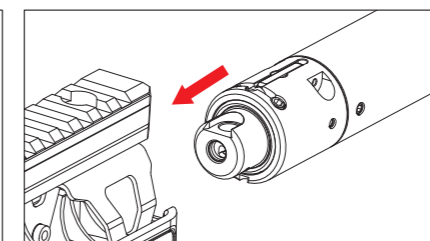

2. 置入槍管組前，請確認槍管保險已解除，並確保槍管固定螺絲已鬆開，之後把HOP-UP座的接口(切平面，如上圖)垂直朝上，再慢慢地將槍管組推進至槍身內部。
2. Before installing the complete barrel set, make sure that 1. the barrel lock is off 2. Barrel Fixing Screw is loosened. Position the HOP-UP tunnel upward like picture in above, then push the barrel set slowly into the receiver/body.

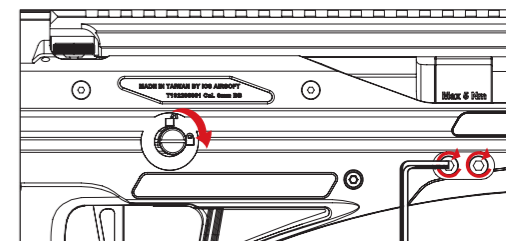

3. 順時鐘旋轉槍管保險鈕至保險位置，並將槍管固定螺絲鎖緊。
※ 建議最大扭力5NM。
3. Set the barrel lock on the lock position and tighten the 2 barrel attachment screws.
※ Recommend torque: 5NM.

WARNING 警告

1. 拆換槍管時要注意入彈管避免碰撞損壞。
2. 外槍管固定螺絲建議使用5NM力道鎖附。
3. 拆換槍管時，請先將HOP調整螺絲放鬆，以免更換時碰撞損壞。
4. 保持汽缸組是未上膛狀況，並確保裝入時汽缸組與槍管是完美對齊。
5. 不要將HOP調整螺絲擰的過緊，否則會損壞HOP皮、壓點、壓桿。
6. 不要將內管固定螺絲擰的過緊，否則會損壞內管。
7. 如果槍管沒有正確固定，請勿開火，否則會損壞槍管。
8. 請勿在保險模式時將汽缸組裝入，否則會損壞扳機連桿。
9. 請勿在汽缸組未至定位/鎖定期時扣動扳機，否則會損壞機匣。
10. 插入彈匣時請注意卡扣位置以防功能不正常。
11. 不要讓彈匣裝填過多BB彈，否則會損壞彈匣彈簧。
12. 不要在沒有槍管組的情況下進行空槍射擊，否則會損壞機匣。
13. 存放時，鋼材質零件應保持油潤，以免生鏽。
14. 請勿在汽缸組、活塞等動作前未保持油潤狀態下使用。
15. 當活塞定位在後時，請勿嘗試拆下尾頂桿，以免危險。
16. 進行任何拆解動作前，請先確保槍口內沒有BB彈。
17. 注意勿將手指放入活塞作動區域以免夾傷。
18. 彈匣有BB彈時，若在拉過一次氣室組並復位後(不論成功上膛與否)，又再一次拉動氣室組會導致多發BB彈進入HOP組，造成功能異常。
19. 請勿長時間讓活塞處於上膛位置，避免彈簧快速疲乏。

使用之注意事項 Maintenance

1. When disassembling the barrel, please avoid any sudden impact.
2. Please tighten MT-32 "Outer Barrel Fixing Screw" at torque 5NM.
3. Please loosen the MT-35 "HOP-adjusting Screw" before disassembling the barrel.
4. Please keep the cylinder unloaded while not using and be sure the barrel is properly aligned with it when installing.
5. Please do not overly tighten the MT-35 "HOP-adjusting Screw" which might cause damage on HOP rubber, nub and lever.
6. Please do not overly tighten the MT-16 "Inner Barrel Fixing Screw" which might cause damage on the barrel.
7. Please do not fire before the barrel is properly aligned and installed.
8. Please unlock the safety before installing the cylinder set.
9. Please do not pull the trigger before the bolt handle is in forward position or when safety is locked.
10. When loading the magazine, please ensure the grooves are aimed to the correct position.
11. Please load BB pellets with proper amount otherwise it might cause damage the magazine feeding spring.
12. Please do not operate any mechanism before the barrel is properly installed.
13. Ensure all metal parts are lubricated when stocking to avoid getting rusty.
14. Make sure the cylinder and piston are properly lubricated before operating.
15. Before disassembling the spring guide, please make sure the piston is unloaded.
16. Clean the barrel and make sure no BB pellets exist before any dissembling move.
17. Keep your hand away from the bolt-action area to avoid any injury might occur.
18. When using, please commit a shot after a single lock & load action. Do not repeat the action more than one time before any firing move.
19. Please do not let piston stay in lock & loaded status for long time to avoid fatigue on the spring.

5 槍托與槍栓拆裝方式 Buttpad and Bolt Assembly and Disassembly

5-1 卸下槍托 Disassembly Buttpad

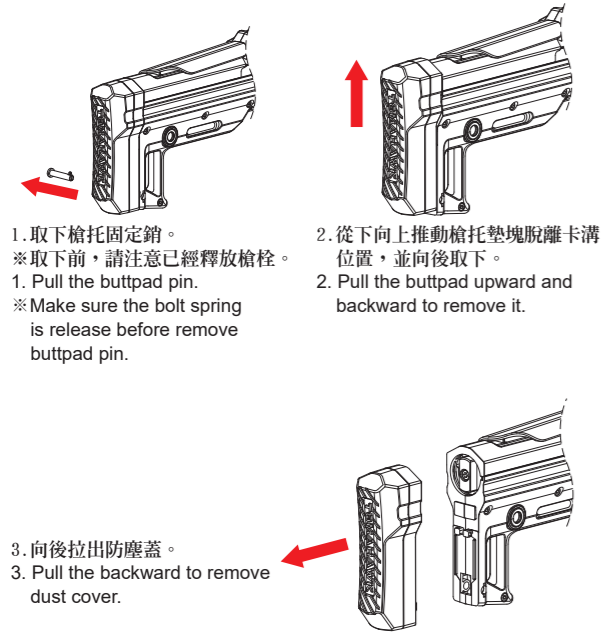

- 取下槍托固定銷。
※取下前，請注意已經釋放槍栓。
1. Pull the buttpad pin.
※Make sure the bolt spring is release before remove buttpad pin.
- 從下向上推動槍托墊塊脫離卡溝位置，並向後取下。
2. Pull the buttpad upward and backward to remove it.
- 向後拉出防塵蓋。
3. Pull the backward to remove dust cover.

5-2 卸下槍栓 Disassembly Bolt

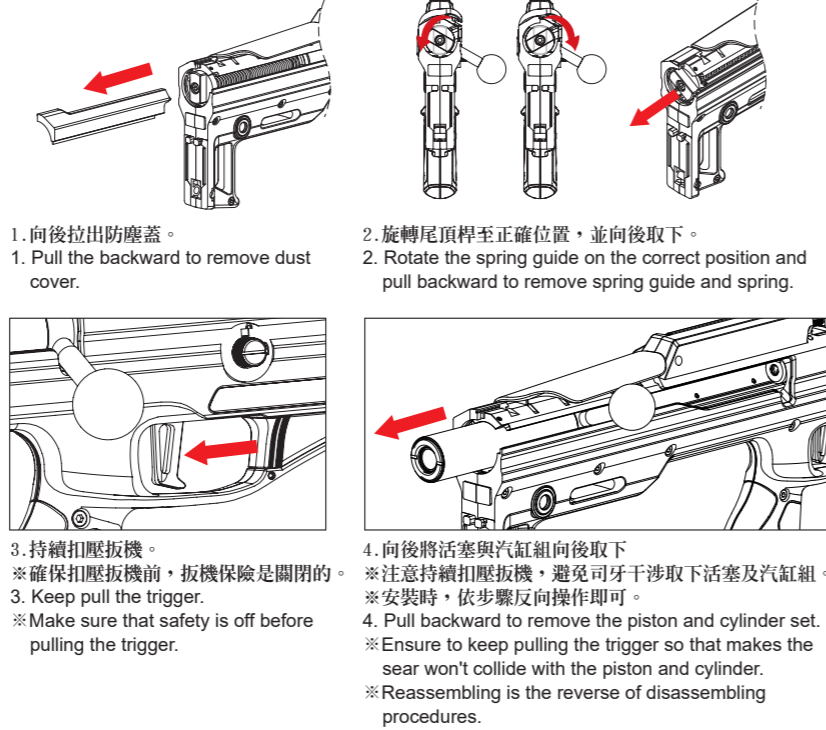

- 向後拉出防塵蓋。
1. Pull the backward to remove dust cover.
- 旋轉尾頂桿至正確位置，並向後取下。
2. Rotate the spring guide on the correct position and pull backward to remove spring guide and spring.
- 持續扣壓扳機。
※確保扣壓扳機前，扳機保險是關閉的。
3. Keep pull the trigger.
※Make sure that safety is off before pulling the trigger.
- 向後將活塞與汽缸組向後取下。
※注意持續扣壓扳機，避免司牙干涉取下活塞及汽缸組。
※安裝時，依步驟反向操作即可。
4. Pull backward to remove the piston and cylinder set.
※Ensure to keep pulling the trigger so that the sear won't collide with the piston and cylinder.
※Reassembling is the reverse of disassembling procedures.

6 貼塞調整 Cheekpad Adjustment

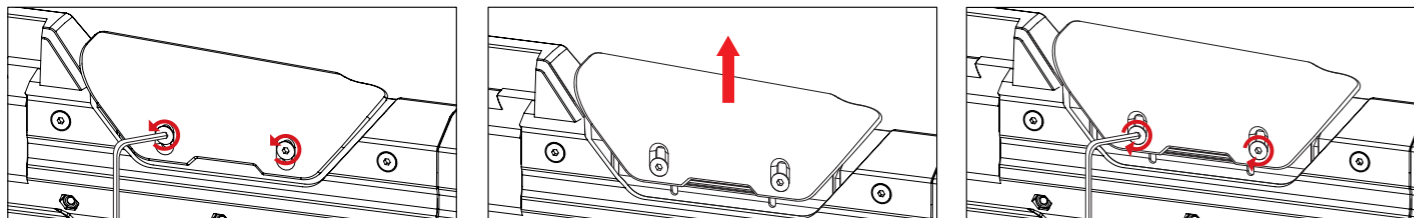

- 旋轉並鬆開貼塞固定螺絲。
1. Loosen the cheekpad screws.
- 上下調整貼塞至適當高度後（個段位）。
2. Adjust the cheekpad position (position allowed).
- 將貼塞螺絲鎖緊。
3. Tighten the screws.

7 射擊操作方式 Shooting Action

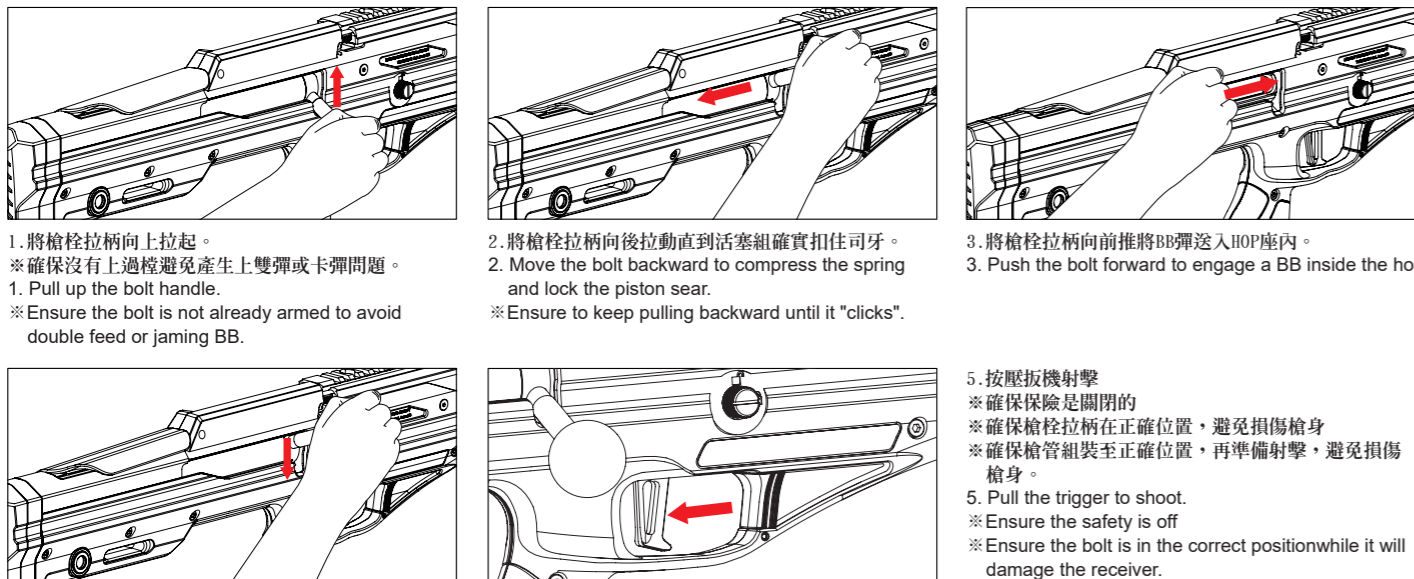

- 將槍栓拉柄向上拉起。
※確保沒有上過檔避免產生上雙彈或卡彈問題。
1. Pull up the bolt handle.
※Ensure the bolt is not already armed to avoid double feed or jamming BB.
- 將槍栓拉柄向後拉動直到活塞組確實扣住司牙。
2. Move the bolt backward to compress the spring and lock the piston sear.
※Ensure to keep pulling backward until it "clicks".
- 將槍栓拉柄向前推將BB彈送入HOP座內。
3. Push the bolt forward to engage a BB inside the hop.
- 將槍栓拉柄向下扣至定位。
4. Lock down the bolt handle to lock the bolt.
- 按壓扳機射擊。
※確保保險是關閉的。
※確保槍栓拉柄在正確位置，避免損傷槍身。
※確保槍管組裝至正確位置，再準備射擊，避免損傷槍身。
5. Pull the trigger to shoot.
※Ensure the safety is off
※Ensure the bolt is in the correct position while it will damage the receiver.
※Do not shoot without barrel assembly installed, it will damage the receiver.

8 Hop調整 Hop Adjustment

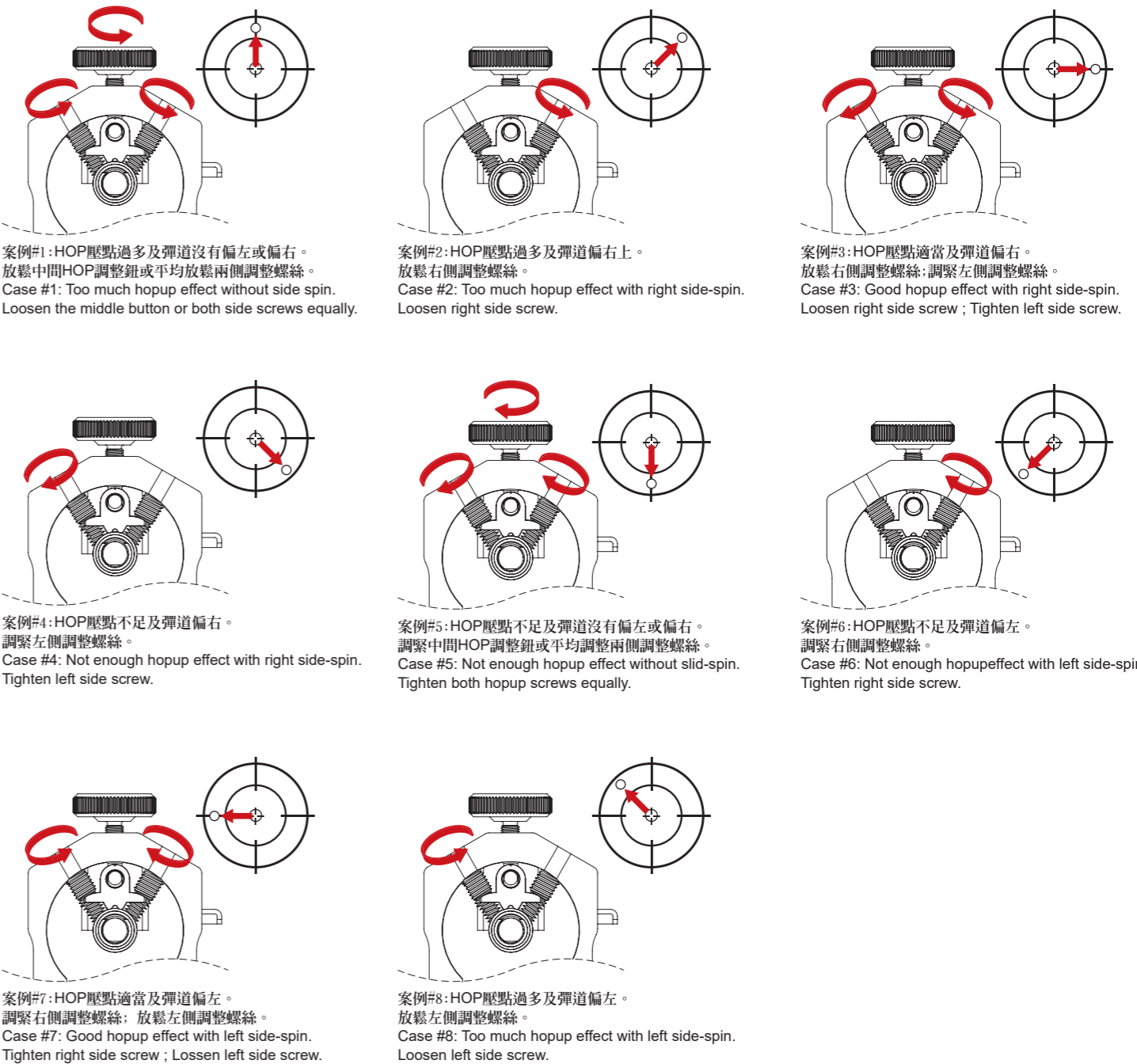

- 案例#1: HOP壓點過多及彈道沒有偏左或偏右。
放鬆中間HOP調整鈕或平均放鬆兩側調整螺絲。
Case #1: Too much hopup effect without side spin.
Loosen the middle button or both side screws equally.
- 案例#2: HOP壓點過多及彈道偏右上。
放鬆右側調整螺絲。
Case #2: Too much hopup effect with right side-spin.
Loosen right side screw.
- 案例#3: HOP壓點適當及彈道偏右。
放鬆右側調整螺絲; 調整左側調整螺絲。
Case #3: Good hopup effect with right side-spin.
Loosen right side screw ; Tighten left side screw.
- 案例#4: HOP壓點不足及彈道偏右。
調整左側調整螺絲。
Case #4: Not enough hopup effect with right side-spin.
Tighten left side screw.
- 案例#5: HOP壓點不足及彈道沒有偏左或偏右。
調整中間HOP調整鈕或平均調整兩側調整螺絲。
Case #5: Not enough hopup effect without side-spin.
Tighten both hopup screws equally.
- 案例#6: HOP壓點不足及彈道偏左。
調整右側調整螺絲。
Case #6: Not enough hopup effect with left side-spin.
Tighten right side screw.
- 案例#7: HOP壓點適當及彈道偏左。
調整右側調整螺絲; 放鬆左側調整螺絲。
Case #7: Good hopup effect with left side-spin.
Tighten right side screw ; Loosen left side screw.
- 案例#8: HOP壓點過多及彈道偏左。
放鬆左側調整螺絲。
Case #8: Too much hopup effect with left side-spin.
Loosen left side screw.

WARNING 警告

- 請勿使用劣質或回收BB彈，以減少槍管損耗及避免卡彈。
- 一旦發生卡彈，應立即停止射擊。請使用通條將殘彈清除並檢測故障原因。
- 不使用本產品時，請務必將射擊選擇鈕置於保險(S)的位置上，釋放彈簧並定期使用通條清潔槍管。
- 請依原廠所配置的彈簧使用(依地區不同而變化)，若私自變更彈簧造成初速超過當地法規規定，ICS不負任何相關法律責任。
- 彈頭直徑6mm，其槍口動能為二焦耳以下，射程範圍為50公尺以內。適用年齡為18歲以上。
- 適用年齡為18歲以上。
- 使用本商品不得改造或變造(易碎貼紙受損視同已變更原廠設定，ICS不負任何相關法律責任)，並不得使用金屬彈頭。
- 「此槍非玩具」，濫用可能造成嚴重傷害，尤其是眼睛。使用時應確保本身及射程範圍內所有人員均已確實穿戴護目鏡。
- 使用方法及注意事項請詳閱說明書內容。

使用之注意事項 Maintenance

- To reduce the abrasion of inner barrel and to avoid BB jam, please do not use inferior or reused BB pellets.
- If your gun is jammed or the muzzle velocity has decreased, please stop shooting immediately in case the gear abrades excessively. Use the clearing rod to clear out the remaining pellets.
- Please engage the safety, clear the inner barrel with the clearing rod periodically when not using this product.
- Please use the same fuse specification as the original one. Equipping improper fuse might cause malfunction to the components.
- The diameter of the BB pellet is 6mm. The muzzle energy is less than two joules, and the shooting range is within 50 meters.
- The recommended age to operate this product is 18 years old and above.
- Modify, reform, and using metal bullets on this product are strictly forbidden.
- This is NOT a toy. Abusing might cause severe injuries, especially to the eyes. Before operating, please make sure that every personnel in the shooting range have worn eye protections properly, including the operator.
- Please read the manual for instruction and precaution.

(原產地: 台灣 / 製造商: 一芝軒企業有限公司 / 地址: 台中市神岡區東洲路79巷67號 / 電話: 04-25256461)

Origin: Taiwan / Manufacturer: ICS enterprise Co., Ltd / Address: No.67, Ln. 79, Dongzhou Rd., Shengang Dist., Taichung City 429, Taiwan / TEL: (+886) 4-2525-6461



BE A GAME CHANGER
ICS AIRSOFT

9

各部零件說明 Description

ICS-450 CXP-TOMAHAWK

*每一款槍型基本配備不同依實際出貨為主。圖片僅供參考。
The components/accessories for each model may have kind of differences depending on the actual goods. Images are only for reference.

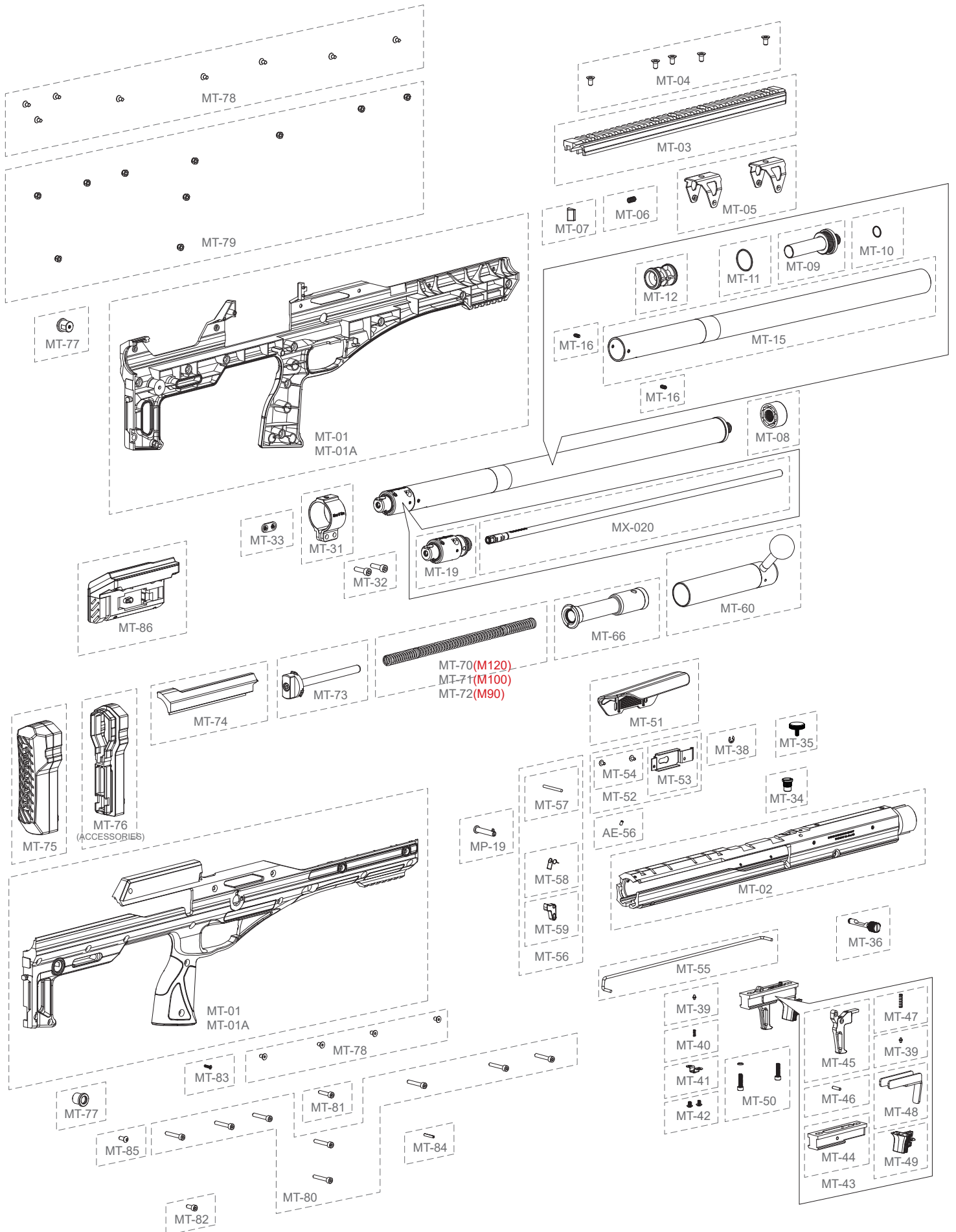

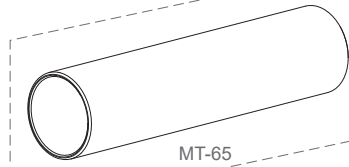

MT-65



MT-11

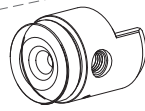

MT-63



MT-62



MT-61

MT-60

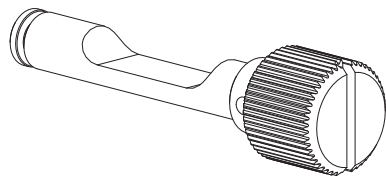

MT-36

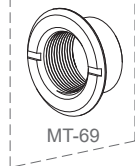

MT-69

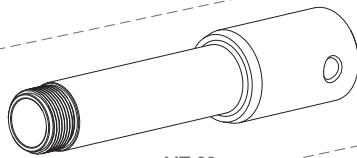

MT-68



MT-67

MT-66

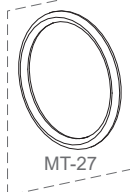

MT-27



MT-26



MT-25



MT-28



MT-29



MT-30

MT-19



MT-21

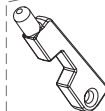

MT-20



MT-24



MT-22



MT-24



AV-08



MT-23



AV-08

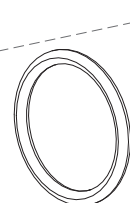

MT-13

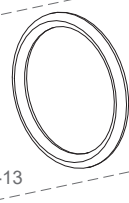

MT-17

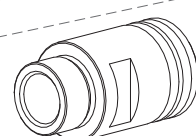

MT-18

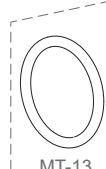

MT-13

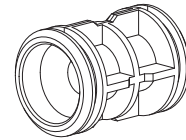

MT-12



MT-14

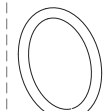

MT-13

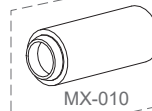

MX-010



MX-012

MX-020

